

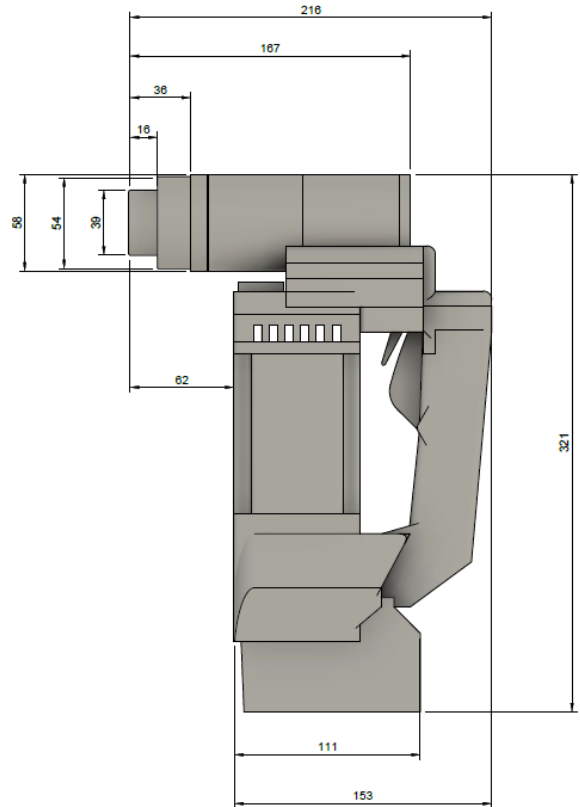

CSM160 Cordless Shear Wrench



Adaptable Bolt Diameter

Metric	M12	M16
Imperial		5/8"

Extension Sockets

Metric	M12x200	M16x200	100mm Extension Holder
Imperial			

Specifications

Model	CSM160-BTL
Motor	DC Brushless Motor
Storage Battery	DC 36V
Rated Max. Torque	294 Nm (217ft lbs)
No-Load Speed	25 rpm
Weight	4.9kg with M16 socket
Battery Capacity (4.0Ah)	Approx. 400 M16 TCBs installed per full charge