

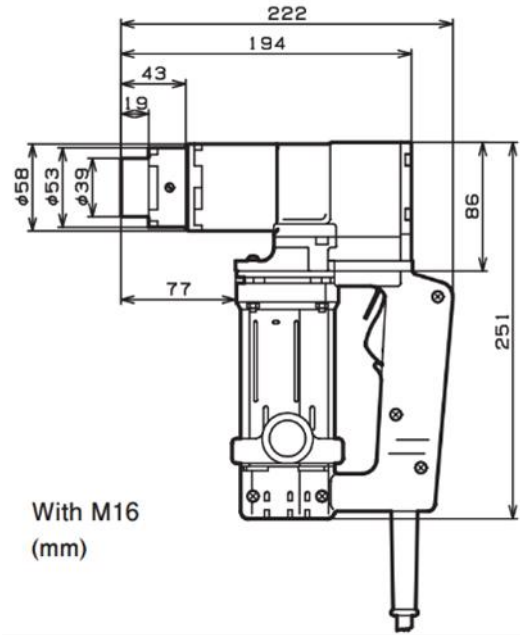

GM160 Electric Shear Wrench



Adaptable Bolt Diameter

Metric	M12	M16
Imperial		5/8"

Extension Sockets

Metric	M12x200	M16x200	100mm Extension Holder
Imperial			

Specifications

Model	GM161EZ	GM162EZ
Rated Voltage (Single Phase)	1102-120V	220-230V
Max. Current	10A	5A
Rated Input Power	1100W	
Frequency	50-60 Hz	
Rated Max. Torque	294 Nm (217ft lbs)	
No-Load Speed	29 rpm	
Weight	4.5 kg (9.9 lb)	
Protection Class	Class II (Double Insulation)	