

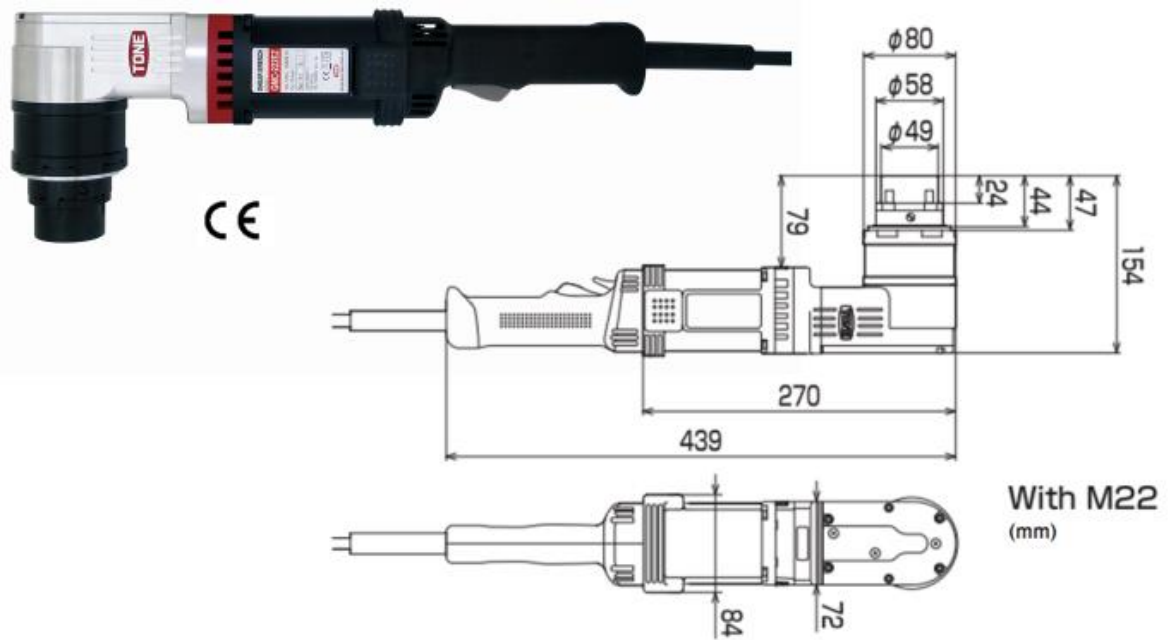

# GMC220 Electric Corner Shear Wrench



## Adaptable Bolt Diameter

Metric	M16	M20	M22
Imperial	5/8"	3/4"	7/8"

## Extension Sockets

Metric	M16x200	M20x200	M22x200	100mm Extension Holder
Imperial				

## Specifications

Model	GMC221EZ	GMC222EZ
Rated Voltage (Single Phase)	110-120V	220-230V
Max. Current	13.5A	7A
Rated Input Power	1550W	
Frequency	50-60 Hz	
Rated Max. Torque	800 Nm (590 ft-lbs)	
No-Load Speed	17 rpm	
Weight	6.2 kg (13.7 lb)	
Protection Class	Class II (Double Insulation)	