

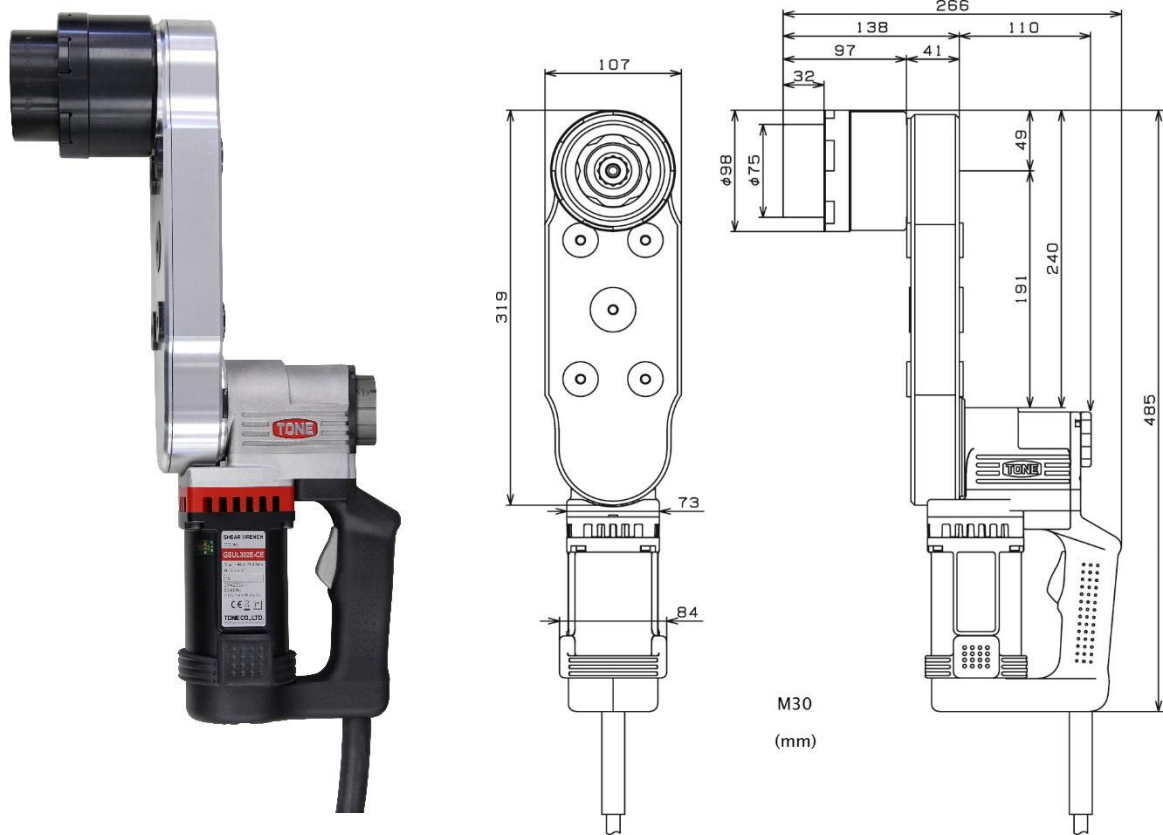

GSULR300 Electric Shear Wrench



Adaptable Bolt Diameter

Metric	M30
--------	-----

Specifications

Model	GSULR301E-CE	GSULR302E-CE
Rated Voltage (Single Phase)	110-120V	220-230V
Max. Current	14A	7.5A
Rated Input Power	1550W	
Frequency	50-60 Hz	
Rated Max. Torque	2150 Nm (1586 ft-lbs)	
No-Load Speed	4.5 rpm	
Weight	12.4 kg (27.3 lb)	
Protection Class	Class II (Double Insulation)	