

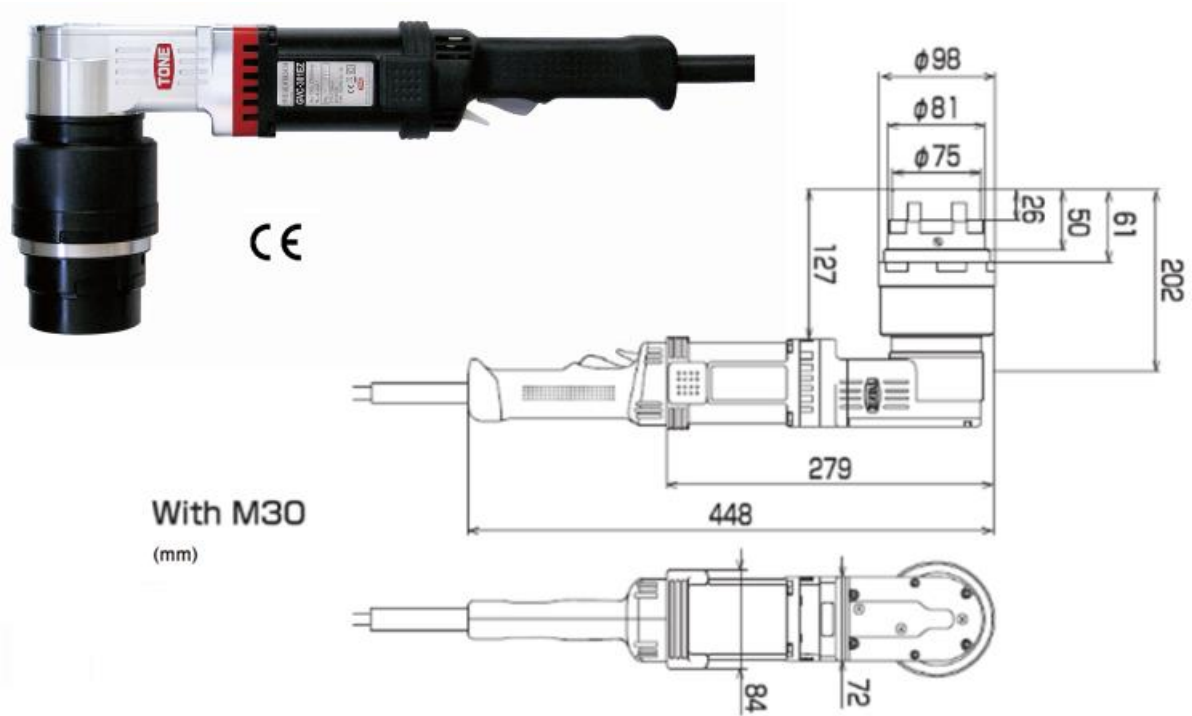

# GVC300 Electric Corner Shear Wrench



With M30  
(mm)

## Adaptable Bolt Diameter

Metric	M27	M30
Imperial	1-1/8"	

## Extension Sockets

Metric	M27x200	M30x200
--------	---------	---------

## Specifications

Model	GVC301EZ	GVC302EZ
Rated Voltage (Single Phase)	110-120V	220-230V
Max. Current	14A	7A
Rated Input Power	1550W	
Frequency	50-60 Hz	
Rated Max. Torque	2150 Nm (1586 ft-lbs)	
No-Load Speed	6 rpm	
Weight	8.8 kg (19.4 lb)	
Protection Class	Class II (Double Insulation)	